

Rinse Station for process carboys and vessels

Our non-metallic rinse station allows users to cost-effectively and efficiently rinse carboys, buckets, and small tanks up to 50 gallons (200 liters). It eliminates the awkward and messy manual rinsing of containers and saves hours of labor. The rinse station also removes the safety risk of wet, slippery floors, since all water is contained within the unit's compact design. It is easy to use, does not require power, and connects directly to a water source and drain. Custom designs for larger vessels are available.

3 Pre-engineered solutions

- Small countertop, medium and large floor standing units
- Handles most carboys & vessels up to 50 gallons (200 liters)

Increase productivity

- Eliminates awkward manual cleaning
- Efficient and easy; quickly get carboys ready for use

Improve safety

- No more wet floors or slip hazards
- Protects operator from splashes, fluid exposure

Easy to use

- Ties in easily with existing water source and standard plumbing
- No electricity required
- Inlet: 1/2" NPT female, Drain: 1 1/2" NPT female

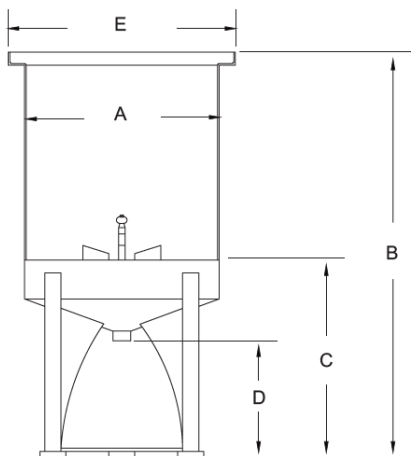

Model	Style	Rinses Vessels up to:	A	B	C	D	E
CTS1443	Countertop	15" Diameter	16"	29"	12.5"	5"	19"
CTS1444	Floor - Standard	18" Diameter	19"	53"	28"	18"	22"
CTS1426	Floor - Large	29" Diameter	30"	63"	30.5"	18"	35"

Countertop Rinse Station



Standard Floor Mount Station



Custom Large Tank Station

